

ROTARY LIFT[®]
The World's Most Trusted Lift[™]



Heavy-Duty Four-Post
Commercial Truck and Transit



18,000 - 30,000 lbs. Capacity Four-Post Lifts (SM Series)

Available Models



Shown: SM300
30,000 lbs. capacity



Shown: SM18
18,000 lbs. capacity



Features and Benefits

Single point release air-locks save valuable working time by releasing all four spring loaded column locks with the push of a single button.

The non-skid surface allows a sure grip for tires and a "sure foot" for technicians standing on the lift.

Automatic ramp chocks engage in the rear when the lift is raised. Drive through models engage in the front and rear.



Shown: SM18
18,000 lbs. capacity shown with optional rolling jacks, bolt-on alignment kit and bolt on work step





Shown: RFL25 - Fork Lift Model
25,000 lbs. capacity

Lift Accessories



A Filter/Regulator/Lubricator supplies clean, lubricated air to your rolling jacks and air powered hand tools for longer life. (standard on SM18 series, optional on SM300 series.)

Internal airline connections let two rolling jacks operate simultaneously. (Standard on SM300 series, optional on SM18)



Rolling jacks with a variety of adapters lift front, rear or all wheels off the runways for brake, tire, alignment and suspension work. When idle, the jacks roll out of the way to provide unobstructed workspace between runways. Auxiliary axle adapters are standard with rolling jacks. (model RJ9000, and FC5710)

Adjustable Nut
Jam Nut
Latch bar



The adjustable latch bar ensures the runways are level at any of the multiple locking positions. (SM18 series only)



Shown: FC5710
15,000 lbs. capacity with flip up adapters



Shown: RJ7000 7,000 lbs. capacity with pad adapters
Also Available: RJ9000
9,000 lbs. capacity with flip up adapters

Front wheel stops can easily be replaced by optional drive through ramps

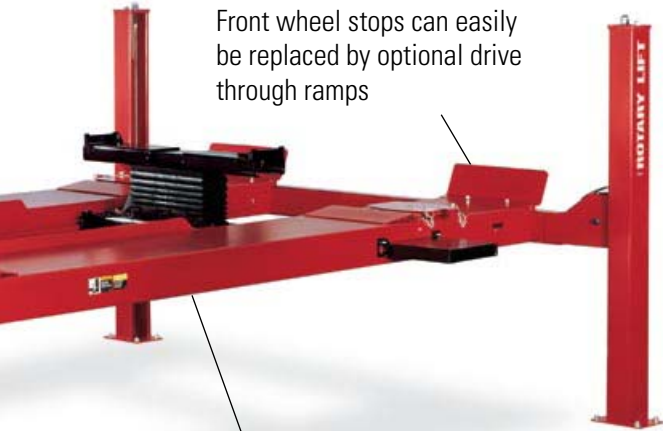

The hydraulic cylinder and lift mechanism is located underneath the runway which eliminates external obstructions that can potentially damage the vehicle doors.

Lube work is made easy when a rolling drain pan with splash guard, drain valve and dust cap is added. An eight foot drain hose with a quick disconnect fitting is also available.



Shown: FC5324
SM18 series, 30 gallon capacity
Also Available: FC5398
SM300 series, 30 gallon capacity

Alignment kits can be added to four-post lifts. Bolt-on alignment kits include a turning radius gauge kit (front) and rear slip plate kit, great assets for alignment work.



Shown: FA5113 for SM18 series lifts.
FC5396 is available for SM300

Visit www.rotarylift.com for more information.



40,000 - 60,000 lbs. Capacity Four-Post Lifts (HDL Series)

Engineered for Performance, Built to Last

Rotary® Four-Post lifts are a great value, an investment that is easy to own and operate because they are engineered to perform and built to last. Our surface lifts accommodate a wide range of vehicles, routine vehicle service and maintenance with a Rotary standard four-post lift is just the ticket.

Take advantage of the quick set-up for undercarriage repairs and wheel service maintenance. These four-post lifts are proven, durable and require little to no maintenance.

Available Models



Features and Benefits

Safety latches in each leg for maximum security.

The non-skid surface allows a sure grip for tires and a "sure foot" for technicians standing on the lift.

Heavy-duty chains ensure runways are level throughout the lifting process.

Fully adjustable runway track width to accommodate any vehicle.

I-Beam construction in runways for maximum capacity.

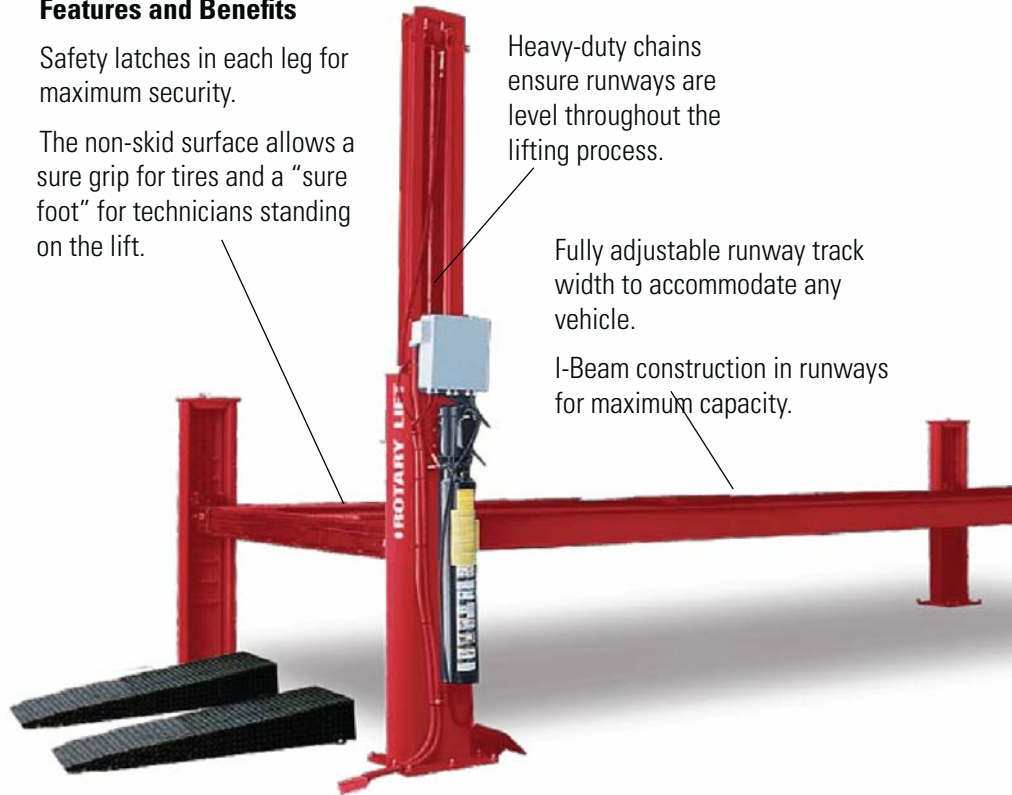

Shown: 40000HDL
40,000 lbs. capacity



Shown: 40000HDL
40,000 lbs. capacity



Shown: 60000HDL
60,000 lbs. capacity
Also Available: 50000HDL
50,000 lbs. capacity

Lift Accessories

Internal airline kit to power rolling jacks and other air tools. Includes 6 quick disconnects, two coil hoses, airline piping and all hardware.



Shown: 994145
Internal airline kit



Front wheel stops can easily be replaced by optional drive through ramps

Rolling jacks with a variety of adapters lift front, rear or all wheels off the runways for brake, tire, alignment and suspension work. When idle, the jacks roll out of the way to provide unobstructed workspace between runways. Auxiliary axle adapters are standard with rolling jacks.



Shown: WK25 25,000 lbs. capacity
rolling bridge jack
Also available:
WK18 18,000 lbs. capacity
WK35 35,000 lbs. capacity



Drive-thru ramps are available and provide a quick and easy on-off service operation.

Two 2-HP motors and two cylinders to provide the tremendous lifting power required for the largest vehicles

Also Available:

- Power unit cover
- Mobile oil drain pans
- Single and 3-phase motors
- Custom colors
- Alignment models are available which include turntable cutouts for two-wheel alignment

Visit www.rotarylif.com for more information.



Heavy-Duty Four-Post Lift Specifications

Identifying Model Numbers

Lift Type	Lift Capacity (x 1000)	Length
SM	18	L

Example:

SM18L = Extended Length Four-Post
18,000 lbs. capacity lift.

Lift Types:

SM..... Standard Four-Post Lift
RFL..... Fork Lift Lift
HDL..... Heavy-Duty Lift

Lengths:

0..... Standard Length
L or 1..... 36" Longer
2..... 72" Longer

Model:	SM18 SM18L	SM300 SM301 SM302	RFL25
Max. Wheelbase	194" (4928mm) 230" (5842mm)	235" (5969mm) 271" (6883mm) 307" (7798mm)	163" (4140mm)
A. Rise	68" (1727mm)	68" (1727mm)	68" (1727mm)
B. Length Overall	22' 11 3/16" (6990mm) 25' 11 3/16" (7904mm)	25' 8 1/8" (7826mm) 28' 8 1/8" (8741mm) 31' 8 1/8" (9655mm)	22' 5" (6833mm)
C. Width Overall	11' 5 3/4" (3499mm)	12' 4 13/16" (3780mm)	12' 4 13/16" (3780mm)
D. Inside of Columns	121 1/2" (3086mm)	132" (3353mm)	132" (3353mm)
E. Between Columns	212" (5385mm) 248" (6299mm)	249" (6325mm) 285" (7239mm) 321" (8153mm)	177" (4496mm)
F. Height of Columns	6' 5 3/4" (1975mm)	7' 3/4" (2153mm)	7' 3/4" (2153mm)
G. Width of Runways	22" (559mm)	24" (610mm)	24" (610mm)
H. Height of Runways	7 1/2" (191mm)	8 3/8" (213mm)	8 3/8" (213mm)
I. Width Between Runways (min./max)	43" (1092mm)/ 46" (1168mm)	41" (1041mm)/ 48" (1219mm)	13" (330mm)/ 48" (1219mm)
Lifting Capacity	18,000 lbs. (8165kg)	30,000 lbs. (13608kg)	25,000 lbs. (11340kg)
Motor	2 HP	4 HP	4 HP
Voltage Single Phase *	208v-230v	208v-230v	208v-230v
Time of Full Rise	100 seconds	105 seconds	105 seconds
Min. Bay Size	16' x 27' (4877 x 8230mm) 16' x 30' (4877 x 9144mm)	16' x 30' (4877 x 9144mm) 16' x 33' (4877 x 10059mm) 16' x 36' (4577 x 10973mm)	16' x 26' (4577 x 7925mm)

* Optional 3-phase electrical available.

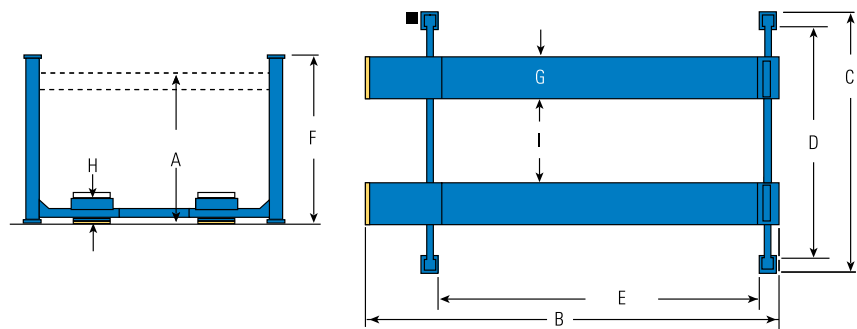

Model:	40000HDL	50000HDL	60000HDL
Max. Wheelbase	25' (7620mm)	30' (9144mm)	33' (10060mm)
Max. Two Wheel Align	22' 6" (6858mm)	27' 6" (8382mm)	30' 6" (9296mm)
A. Rise	68" (1727mm)	68" (1727mm)	68" (1727mm)
B. Length Overall	33' 10" (10312mm)	38' 10" (11840mm)	43' 10" (13360mm)
C. Width Overall	14' 3" (4343mm)	14' 3" (4343mm)	15' 6" (4724mm)
D. Inside of Columns	11' 10" (3607mm)	11' 10" (3607mm)	12' 4" (3759mm)
E. Between Columns	24' 3" (7391mm)	29' 3" (8915mm)	32' 1" (9776mm)
F. Height of Columns	12' 10" (3912mm)	12' 10" (3912mm)	13' 1" (3988mm)
G. Width of Runways	24" (610mm)	24" (610mm)	28" (711mm)
H. Height of Runways	9" (229mm)	9" (229mm)	12" (305mm)
I. Width Between Runways (min/max)	40" / 82" (1016mm / 2083mm)	40" / 82" (1016mm / 2083mm)	40" / 64" (1016mm / 1626mm)
Lifting Capacity	40,000 lbs. (18140kg)	50,000 lbs. (22680kg)	60,000 lbs. (27220kg)
Motor	2 HP x 2	2 HP x 2	3 HP x 2
Voltage 3-Phase †	208v-230v	208v-230v	208v-230v
Time to Full Rise	100 seconds	100 seconds	110 seconds
Min. Bay Size	18' x 38' (5486mm x 11582mm)	18' x 43' (5486mm x 13106mm)	20' x 48' (6096mm x 14630mm)

† Optional single phase electrical available.

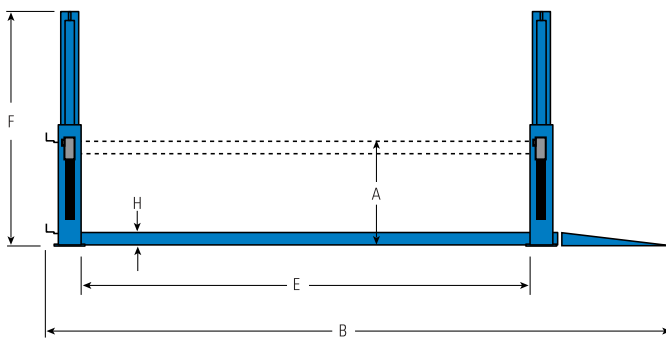
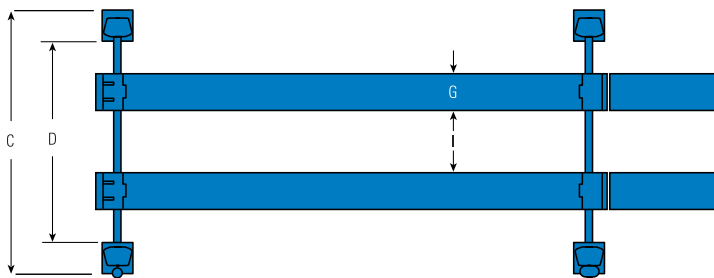

7,000 lbs. and 14,000 lbs. capacity four-post lifts are also available.



Rotary Lift® is the world leader in service bay productivity. We offer a broad range of solutions to make any service bay more productive.

For more information and a complete guide to our product offering, visit us on the web at rotarylif.com or contact your local distributor today.



Rotary Lift is an approved AIA provider assisting in continuing education credits. Contact us for training sessions in your area or online.



Contract Holder
FSS Contract GS07F8953D

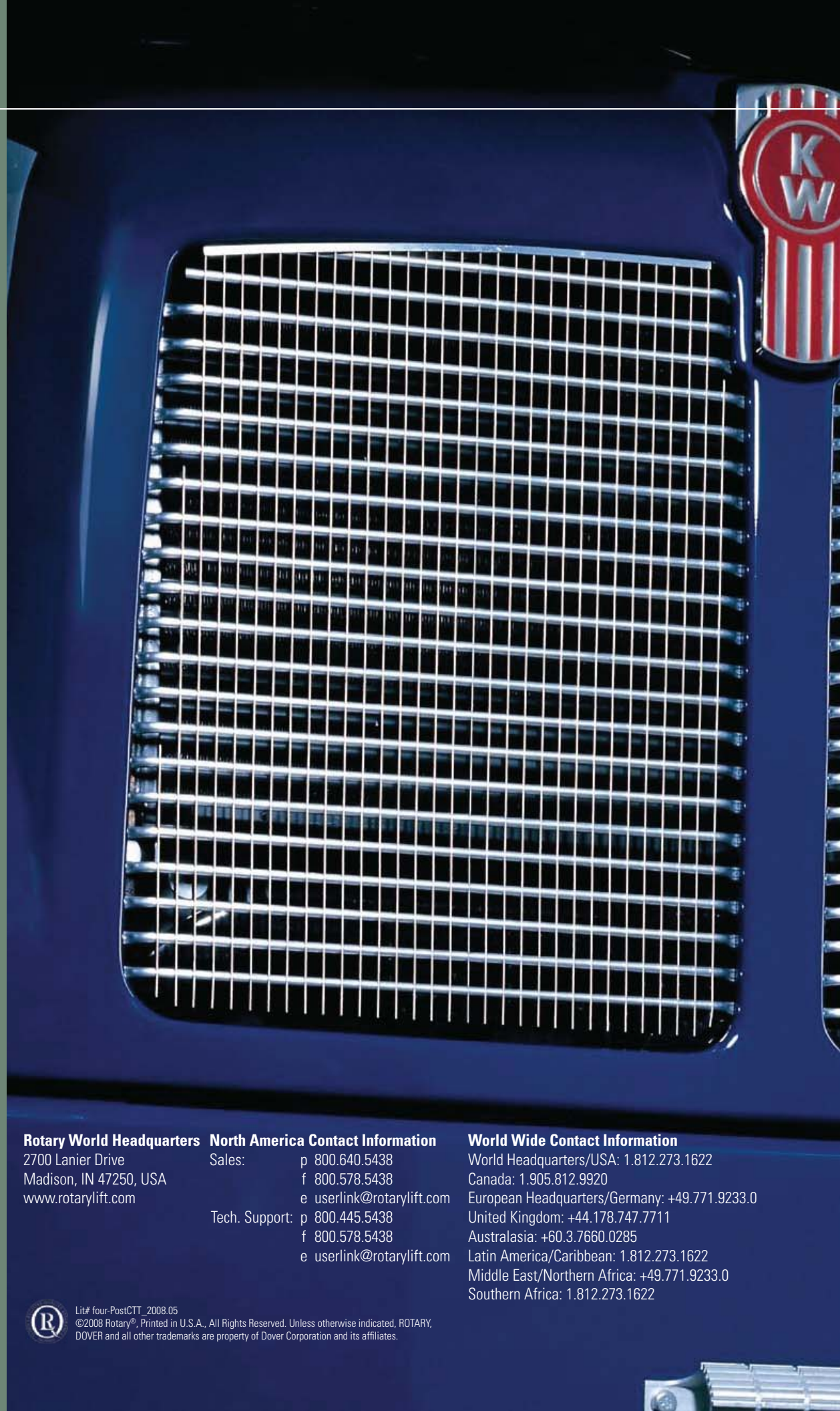

ROTARY LIFT®
The World's Most Trusted Lift



A DOVER™ COMPANY



Rotary World Headquarters North America Contact Information

2700 Lanier Drive
Madison, IN 47250, USA
www.rotarylif.com

Sales: p 800.640.5438
f 800.578.5438
e userlink@rotarylif.com
Tech. Support: p 800.445.5438
f 800.578.5438
e userlink@rotarylif.com

World Wide Contact Information

World Headquarters/USA: 1.812.273.1622
Canada: 1.905.812.9920
European Headquarters/Germany: +49.771.9233.0
United Kingdom: +44.178.747.7711
Australasia: +60.3.7660.0285
Latin America/Caribbean: 1.812.273.1622
Middle East/Northern Africa: +49.771.9233.0
Southern Africa: 1.812.273.1622



Lit# four-PostCTT_2008.05
©2008 Rotary®, Printed in U.S.A., All Rights Reserved. Unless otherwise indicated, ROTARY, DOVER and all other trademarks are property of Dover Corporation and its affiliates.